



SEMI-CIRCULAR WASHFOUNTAINS



Guidance for Installers

Operating Instructions

Fault Finding

Care and Maintenance

Please retain this document for future reference

Acorn Thorn Ltd. 5 Brearley Court Baird Road Waterwells Business Park Gloucester GL2 2AF
Tel: 01452 721211 www.acornthorn.co.uk

Each Apinox Washfountain is supplied with a full operation and maintenance manual and a tool kit to enable proper installation and subsequent maintenance.
THESE MUST BE HANDED OVER TO THE END USER AFTER INSTALLATION

REPLACEMENT TOOLKIT: £33.00 nett + £10.00 next day carriage

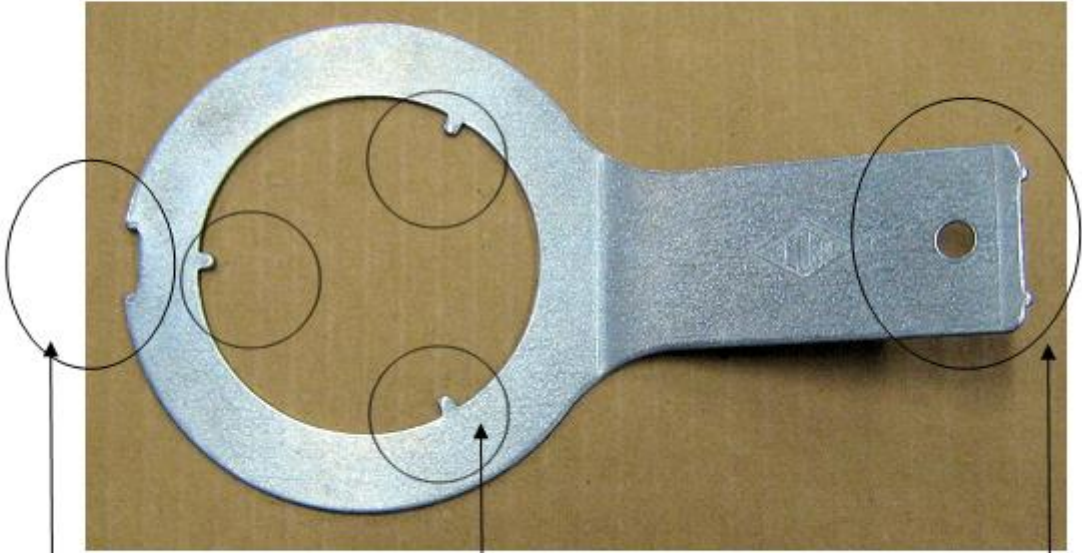

Use for ¼ turn fastener for removal and refitting of old-style soap dispenser lid (pre 2012)

Use for removal of foot push button housing

Use for spray nozzle removal / refitting

The tool shown above is only supplied with FOOT operated units or as part of a replacement tool kit



This tool is used for removal and refitting of spray nozzles only



T27 (left) is used for removal of the new-style soap lid (from 2012 onwards)

T25 (right) is used for the removal and refitting of security drive screws fitted to the pedestal access panel.
Note: depending on model, the T25 size tool is sometimes provided to the design shown at far right





Special Features

- ▲ STAINLESS STEEL CONSTRUCTION
- ▲ SPACE AND ENERGY SAVING
- ▲ FACTORY ASSEMBLED FOR EASY, LOW COST INSTALLATION
- ▲ HYGIENIC AND VANDAL RESISTANT
- ▲ JUNIOR HEIGHT OPTION AVAILABLE

Description

The semi-circular washfountain is ideal for applications where several people will be washing their hands at the same time in locations such as factories, schools, colleges, sporting and entertainment venues. Compared to traditional basins the washfountain offers considerable savings in space, water and energy usage and the costs associated with installation and long term maintenance. Individual water saving control of each outlet is standard, whether activated by the hand push button valve, the foot operated valve or the non-touch infra red sensor. All valves and pipework are fully concealed. Installation time and cost is dramatically reduced as the washfountain is delivered fully assembled, complete with an integral liquid soap dispensing system. The semi-circular washfountain will accommodate 4 users and is available in standard (adult) or junior heights.

Construction

The bowl of the washfountain is formed in one piece from heavy gauge 1.9 mm thick grade 304 stainless steel. The sectional spray head, support tube and scuff base panels are also manufactured from 304 grade stainless steel. The stainless steel pedestal panels are held in position by security type screws. The washfountain is supplied fully assembled complete with an integral liquid soap dispensing system and an unslotted grated waste fitting.

Operation

Each water outlet has a vandal resistant spray nozzle which provides a concentrated spray and is actuated by its own valve.

Hand operation: Hand push buttons activate timed flow valves with an adjustable flow duration of 5 to 60 seconds.

Foot operation: Individual foot operated valves activate water as long as the foot push button is depressed.

Sensor operation: Sensor operation can be supplied using non-touch infra red sensors which control the flow of water from each outlet. This control method is recommended for use in schools by the BSF (Building Schools for the Future) guidelines.

Designed to accept water supply pipework from below or from the rear, the washfountain can be modified for overhead supplies and, if required, a shroud is available to conceal the pipework.

Options

- ▲ TMV3 Thermostatic mixing valve
- ▲ Stainless steel overhead telescopic pipe shroud.

Order Codes and Technical Specification

Please refer to the Technical Specification Sheet

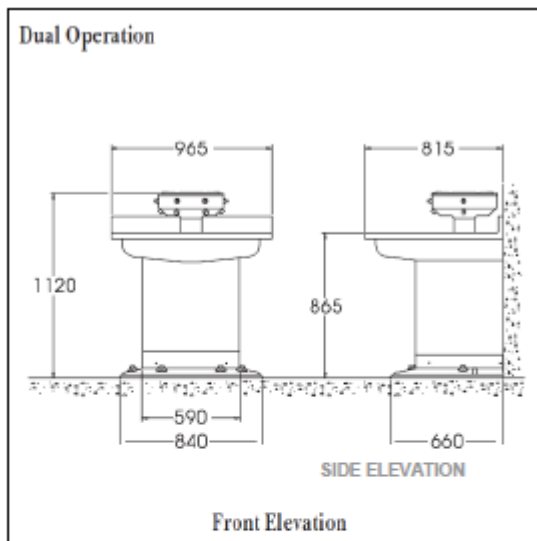
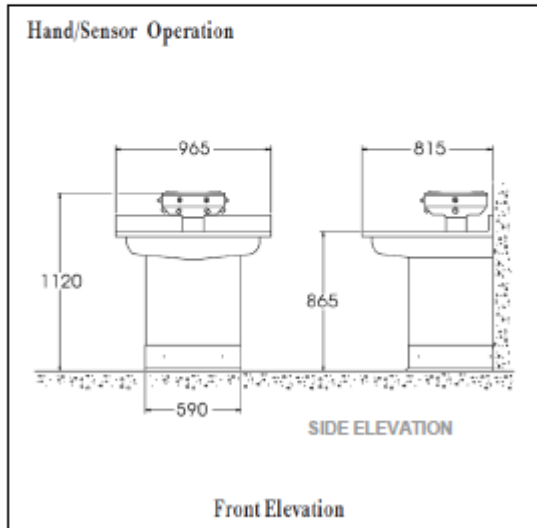

Size and Number of Users

The semi-circular washfountain will accommodate 4 users simultaneously.

Operation

Hand Operation: hand operated push buttons activate individual timed flow valves which can be adjusted for flow operation ranging from 5 to 30 seconds.

Foot Operation: individual foot operated valves activate water flow as long as the foot push button is depressed.

Sensor Operation: sensor operation provides non-touch control of individual water outlets. The water flow is activated as long as the user's hands are within the bowl area. The sensor operated washfountain is supplied with a 240VAC/24VAC transformer for remote siting.

Fittings

The washfountain is supplied fully assembled with the following fittings:

- ◆ Liquid soap dispensing system built into the stainless steel spray head assembly.
- ◆ Unslotted grated waste fitting with 38 OD x 100 mm long (1½ OD x 4 in long) plain spigot tail piece.

Optional Fitting

- ◆ Supplied loose for installation within the pedestal is the optional TMV3 thermostatic mixing valve with isolating valve and test point

Water Supply and Pressure

Hot and cold water supply pipes should be a minimum of 28 mm diameter reducing in size for 22 mm within the pedestal immediately before the TMV3 thermostatic mixing valve. For satisfactory operation a minimum 1.5 bar g. pressure is required for each supply where the water enters the washfountain pedestal. For pressures in excess of 7.0 bar g. a flow control reducing valve must be fitted.

Product Code Selection for Order or Quotation

1. Base product code

- 364 -washfountain 4 user

2. Operation

- H - Hand
- F - Foot
- SO - Sensor

3. Water Supply

- BS -Bottom -TS -Top

4. Option

- TMV3-22 TMV3 Thermostatic mixing valve.
- OS -Overhead pipe shroud Top water supply only: specify floor to ceiling height _____ mm)
- JH -Junior height fitting kit (reduces floor to bowl rim height from 864 mm to 659 mm)

As improvements in the design and performance of Acorn Thorn Limited products is continuous specifications may be subject to change without notification

INSTRUCTIONS FOR BREAK DOWN OF WASH FOUNTAIN WITH LIMITED ACCESS TO INSTALLATION POINT

HAND OPERATION AND SENSOR OPERATION ONLY

1. Remove all pedestal panels using the allen key provided carefully noting the position of the smaller access panel. **Note** that there are two short screws which **must** be re-fitted in the correct position.
2. Remove the entire valve tree from its mounting bracket.
3. Remove the four hex head bolts and nuts that secure the tops of the legs to the bowl. Make sure that the bowl assembly is supported at all stages when these bolts are out and no stress is put on the water tubes, air tubes or cables attaching to the valve tree to the spray heads/hand push buttons/sensors (3 person job ideally).
4. The bowl and valve tree and the base and legs can now be carried to the installation point and reassembly is a straightforward reversal of the above steps. Care must be taken when fitting the panels not to cross thread the fixing screws as that will render both the screw and captive nut useless.

Please ensure that adequate support of the wash fountain is provided at all stages of the above procedure.

If you wish to call before carrying out this procedure so that we can advise you of any possible snags that you may encounter please telephone on 01452 721211.

INSTRUCTIONS FOR BREAK DOWN OF WASH FOUNTAIN WITH LIMITED ACCESS TO INSTALLATION POINT

FOOT OPERATION ONLY

1. Remove all pedestal panels using the allen key provided carefully noting the position of the smaller access panel. **Note** that there are two short screws which **must** be re-fitted in the correct position.
2. Disconnect the colour coded water tubes from the valves by undoing the white nylon compression nuts.
3. Mark one of the legs and the bowl to ensure they are matched when reassembling. Remove the four hex head bolts and nuts that secure the tops of the legs to the bowl. Make sure that the bowl assembly is supported at all stages when these bolts are out and no stress is put on the water tubes attached to the spray heads (3 person job ideally).
4. The bowl and valve tree and the base and legs can now be carried to the installation point and reassembly is a straightforward reversal of the above steps. Care must be taken when fitting the panels not to cross thread the fixing screws as that will render both the screw and captive nut useless.

Please ensure that adequate support of the wash fountain is provided at all stages of the above procedure.

If you wish to call before carrying out this procedure so that we can advise you of any possible snags that you may encounter please telephone on 01452 721211.

Installation and Maintenance Instructions

Apinox Product Code 364 Semi-Circular Wash Trough

Model 364 installation

Floor anchoring points (A):

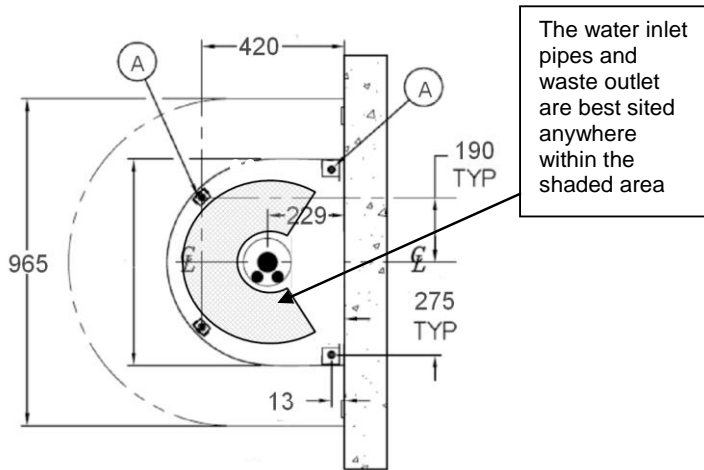

The water inlet pipes and waste outlet are best sited anywhere within the shaded area

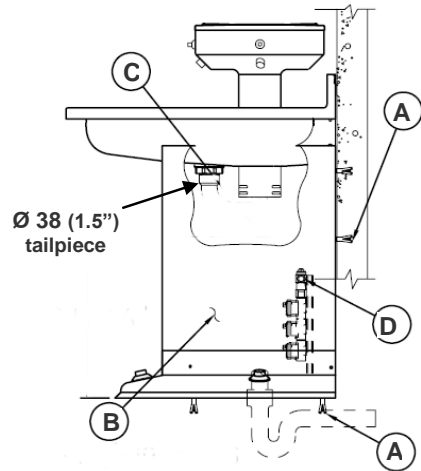

PLAN VIEW OF PEDESTAL UNIT

ELEVATION VIEW OF 364 FOUNTAIN WITH FOOT PEDAL

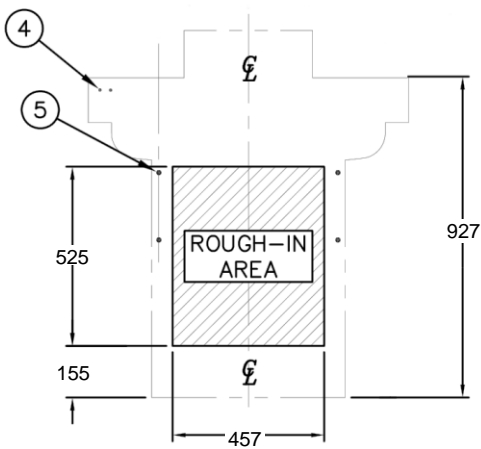

ROUGH-IN AREA

- 1) Remove pedestal skirt quarter panel (B)
- 2) Make up installer provided waste (C)
- 3) Install wall & floor anchors (A) and attach fixture to the wall & floor (anchors and anchor hardware to be supplied by installer)
- 4) Ø22 mm inlet stub to valve tree (D)
Flush supply lines before making up connections
- 5) Adjust TMV3 mixing valve to desired temperature if factory setting is not suitable
- 6) Set timing cycle on metering valves
- 7) Reinstall pedestal skirt quarter panel
- 8) For junior height (JH) model reduce vertical heights shown in rough-in diagram (at left) by 205mm
Height to rim is 659mm for the junior model (JH)
- 9) 4 and 5 on the rough-in diagram indicate fixing points

Notes:

Min working pressure: 1.5 bar
Max working pressure: 7.0 bar
Max outlet temperature: 40°C:

Earthing Continuity: The trough is provided with a number of fixing points on to which an earthing continuity wire with an end terminal can be secured

Please see our [Care and Maintenance](#) information sheet for routine care and cleaning
Caution: turn off supply and drain if subjected to freezing temperatures

FAULT FINDING

Sensor Operation

Drawing reference: 9940-010-002

START UP MODE:

The Acorn –S0 is a 24VAC sensor and includes a manual range adjustment. Sensor range adjustments may be made using adjustment screw on back of sensor.

The Start Up Mode will take approximately five (5) minutes to complete its full cycle and it is important that no target is present in front of the sensor during this time. A steady red light visible in the center of the oval sensor window indicates the sensor is in Start Up Mode. If the red light is flashing, this indicates that the sensor is picking up a target. Unless this target is a permanent fixture in the sensor's environment (i.e. a wall or stall door) it must be removed from the view of the sensor. If this target is permanent the sensor will attempt to adapt itself around this target. When Start Up Mode is complete the steady red light will go off.

NOTE:

1. If the 24VAC power supply is interrupted for more than fifteen (15) seconds the Start Up Mode will automatically repeat itself when the power is restored.
2. If the indicator light flashes three (3) times quickly, then three (3) times slowly and continues to repeat this sequence, this indicates incorrect wiring or a short in the 24VAC power supply.

NORMAL VALVE FUNCTION:

One second time delay when sensor is activated by user. Time of flow is 30 seconds. To reactivate, the user must move out of and return to the sensing area. When installed in the shower, flow continues indefinitely until user moves from sensing area.

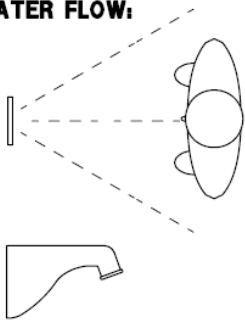
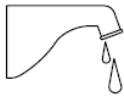
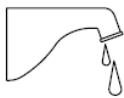
CONDITION:	PROBABLE CAUSE
<p>NO WATER FLOW:</p> 	<ol style="list-style-type: none"> 1.1 Stops or main water supply may be closed. 1.2 When using –MXP or –MXT mixing valve, both supplies must be open to supply adequate water flow. 1.3 Clogged strainer. 1.4 Clogged water diaphragm. 1.5 Loose wiring connections. 1.6 Blown fuse at transformer. 1.7 Circuit breaker shut off.
<p>WATER WON'T SHUT OFF</p> 	<ol style="list-style-type: none"> 2.1 Adjacent objects may be triggering the sensor. 2.2 Sensor malfunction.
<p>WATER DRIPS</p> 	<ol style="list-style-type: none"> 3.1 Clogged water diaphragm.

MINIMUM / MAXIMUM WATER PRESSURE (PSI) 30 / 125. MAXIMUM WATER TEMPERATURE 130°F.
Refer to drawing #9955-015-002 for parts breakdown of items listed above.

Refer to Acorn Operations And Maintenance Manual for installation instructions and repair parts.

FAULT FINDING

Hand / Foot Operation
Drawing reference: 9940-000-002

AIR-CONTROLLED VALVES - (DIRECT ACTING)

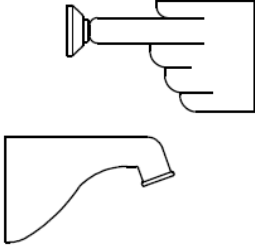
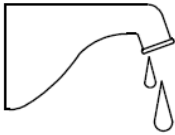
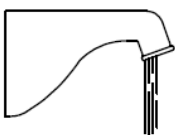
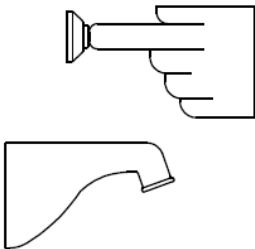
CONDITION:	SOLUTION:
<p>NO WATER FLOW:</p> 	<ol style="list-style-type: none"> 1.1 Check water main supply – open. 1.2 Inspect checkstops – open. 1.3 Inspect checkstop strainer for debris. 1.4 Check 1/8” O.D. tubing and fittings for leaks. 1.5 Check pushbutton air diaphragm for holes. 1.6 Check servomotor diaphragm center hole for blockage.
<p>WATER DRIPS / WONT SHUT OFF:</p> 	<ol style="list-style-type: none"> 2.1 Check servomotor diaphragm offset hole for debris. 2.2 Check servomotor seat for build-up or damage. 2.3 Check servomotor plate and diaphragm for obstruction.
<p>REDUCED WATER FLOW:</p> 	<ol style="list-style-type: none"> 3.1 Check valve riser tubing for crimping. 3.2 Inspect checkstop strainer for debris. 3.3 Check valve flow control for blockage. 3.4 (Washfountains) Check nozzle assembly for debris.
<p>PREMATURE WATER SHUTOFF:</p> 	<ol style="list-style-type: none"> 4.1 Check 1/8” O.D. tubing and fittings for leaks. 4.2 Check pushbutton air diaphragm for holes.

THE SOAP DISPENSER

Drawing reference: 9912-260-002



5 Brearley Court, Baird Road, Waterwells Business Park
 Quedgeley, Gloucester GL2 2AF
 Tel: 01452 721211 Fax: 01452 721231

Web: www.acornthorn.co.uk

Care and Maintenance of Stainless Steel

Introduction

All grades of stainless steel will stain and discolour due to surface deposits and can never be accepted as completely maintenance free. In order to achieve maximum corrosion resistance the surface of the stainless steel must be kept clean. Provided the grade of stainless steel and the surface finish are correctly selected, and cleaning schedules carried out on a regular basis, good performance and long service life are assured.

Factors Affecting Maintenance

Surface contamination and the formation of deposits must be prevented. These deposits may be minute particles of iron or rust from other sources used on the building of new premises and not removed until after the stainless steel items have been fixed. Industrial and even naturally occurring atmospheric conditions can produce deposits which can be equally corrosive, e.g. salt deposits from marine conditions.

The working environment also offers more aggressive conditions e.g. hot humidity, such as in a swimming pool, increases the speed of discoloration and therefore requires the maintenance to be on a more frequent basis. Modern processes use many cleaners, sterilizers and bleaches for hygienic purposes. All these proprietary solutions, when used in accordance with makers instructions are safe but if used incorrectly (e.g. warm or concentrated) can cause discoloration and corrosion on the surface of any quality of stainless steel. Strong acid solutions are sometimes used to clean masonry and tiling of buildings but they should never be permitted to come into contact with metals, including stainless steel. If this should happen the acid solution must be removed immediately by copious applications of water.

Maintenance Programme

With care taken during fabrication and installation, cleaning before handing over to the Client should present no special problems, although more attention than normal may be required if the installation period has been prolonged. Where surface contamination is suspected, immediate attention to cleaning after site fixing will encourage a trouble free product. Food handling, pharmaceutical, aerospace and certain nuclear applications require extremely high levels of cleanliness applicable to each industry. Advice is often sought concerning the frequency of cleaning stainless steel and the answer is quite simple "clean the metal when it is dirty in order to restore its original appearance". This may vary from one to four times a year for external applications or it may be once a day for an item in hygienic or aggressive situations. Frequency and cost of cleaning is lower with stainless steel than with many other materials and will often outweigh the initial higher cost of this superior product.

PROBLEM	CLEANING AGENT	COMMENTS
Routine cleaning. All finishes.	Soap or mild detergent and water. (such as Fairy Liquid).	Sponge, rinse with clean water, wipe dry if necessary.
Fingerprints. All finishes.	Soap or warm water or organic solvent (e.g. Usher/Walker Thinners No. PF8017, acetone, alcohol).	Rinse with clean water, wipe dry if necessary.
Stubborn stains and discolouration. All finishes.	Mild cleaning solutions i.e. Jif, Goddard Stainless Steel Care.	Rinse well with clean water and wipe dry.
Rust like marks and other corrosion. All finishes.	Oxalic Acid. The cleaning solution should be applied with a swab and allowed to stand for 15-20 minutes before being washed away with water. May continue using Jif to give final clean.	Rinse well with clean water (precautions for acid cleaners should be observed).
Scratches on brush (Satin) finish.	Slight scratches. Nylon pads with fairy liquid, apply in direction of grain. For deeper scratches; more rubbing required in direction of grain. Then clean with soap or detergent as per routine cleaning.	Do not use ordinary steel wool - iron particles can become embedded in stainless steel and cause further surface problems.

Precautions

Acids should only be used for on-site cleaning when all other methods have been proved unsatisfactory. Rubber gloves should be used and care taken to see that acid cleaners are not spilt over adjacent areas. Special precautions are necessary with oxalic acid. Solvents should not be used in closed places. Smoking must be avoided when using solvents.

REFERENCE DRAWINGS	
REPAIR PARTS	DRAWING
LOTION SOAP (-DV)	9965-230-002
METERING LIQUID SOAP (-PDM)	9965-266-001
MULTI-PURPOSE WRENCH	9951-000-001
1/4 TURN FASTENER ASSY	9951-006-001

NOTE:
WHEN RETROFITTING TO A UNIT WITH A TOP SUPPLY OR VENT, ALL THROUGH TOP CONNECTIONS MUST BE DISCONNECTED PRIOR TO INSTALLATION.

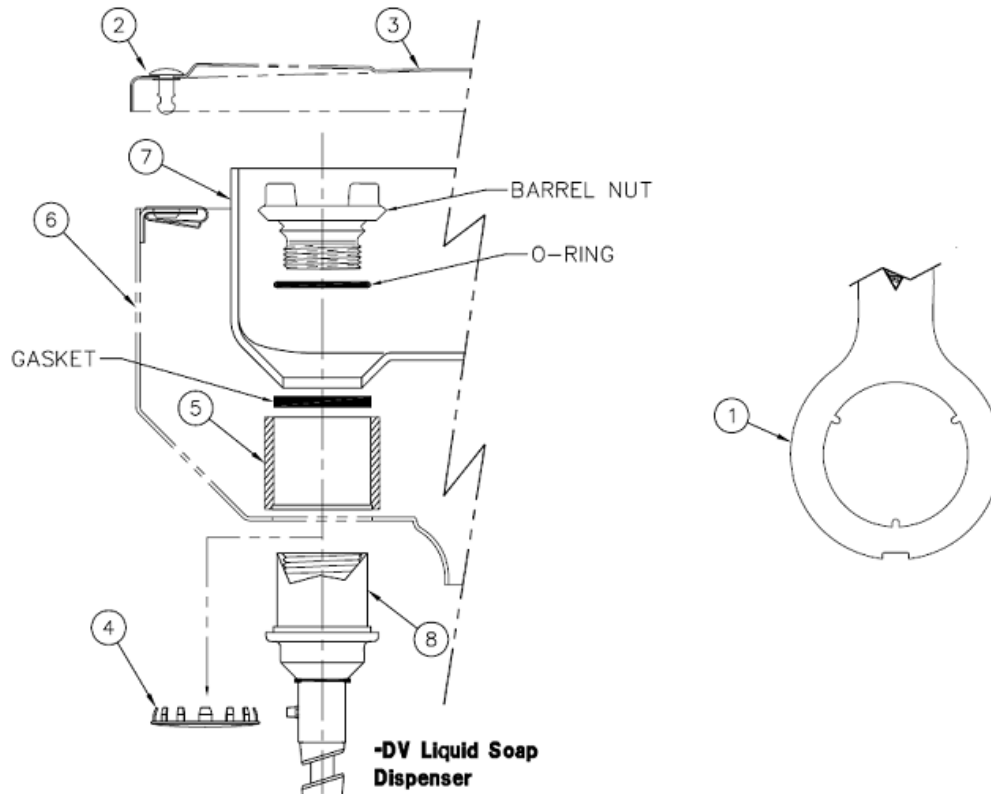

SOAP DISPENSER/TANK INSTALLATION DETAIL

- A- WITH WRENCH (1) PROVIDED GIVE LID FASTENERS (2) A QUARTER TURN COUNTERCLOCKWISE AND REMOVE LID (3).
- B- REMOVE SOAP DISPENSER PLUGS (4). (DISCARD)
- C- POSITION BARREL STANDOFFS (5) OVER HOLES IN SPRAYHEAD (6).
- D- PLACE SOAP TANK (7) INSIDE SPRAYHEAD ALIGNING OPENINGS IN TANK WITH STANDOFFS (5).
- E- ASSEMBLE SOAP DISPENSERS (8) FROM INSIDE SOAP TANK AND BELOW SPRAYHEAD AS SHOWN ABOVE.
- F- FILL SOAP TANK (7) WITH SOAP.
- G- SECURE LID (3) USING SPECIAL WRENCH (1) & TURNING FASTENERS (2) 1/4 TURN CLOCKWISE.

Note: This page shows the tool used for removing soap lids on models manufactured up until 2012. After that date a modified soap dispenser lid has been fitted. Please refer to page 2 of this manual to see comparisons of tools for the two designs.

THE SOAP DISPENSER

Parts Numbers
Drawing reference 9965-230-002

1 COMPLETE ASSEMBLY

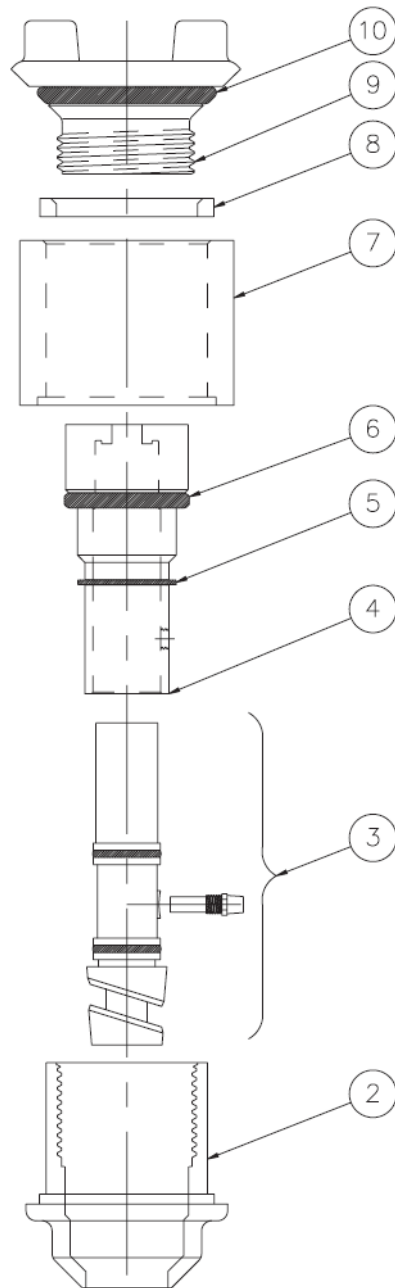

1	1451-010-001	LOTION SOAP DISPENSER	6	0401-212-000	O-RING
2	1450-011-000	BARREL FOR POWDERED SOAP	7	1450-013-199	SPACER
3	1451-010-000	SOAP DISPENSER	8	0430-003-000	GASKET
4	1451-010-199	DISPENSER ADAPTER	9	1450-012-000	BARREL NUT
5	0326-013-000	RETAINING RING	10	0401-220-000	O-RING
ITEM	PART NUMBER	DESCRIPTION	ITEM	PART NUMBER	DESCRIPTION

Spray Nozzle Components

Drawing reference: 9971-001-001

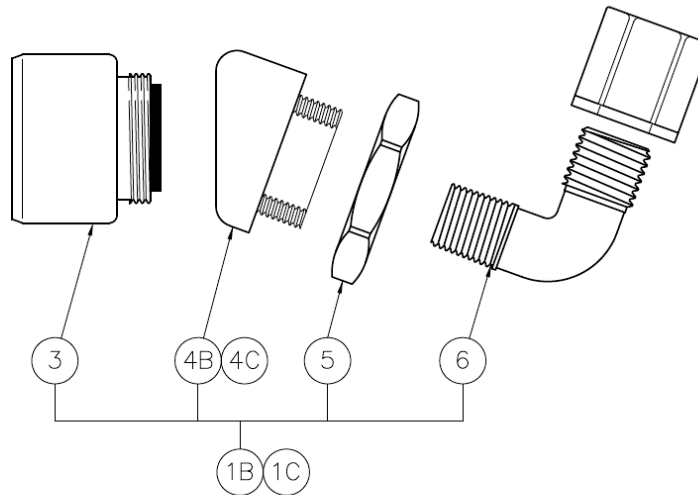
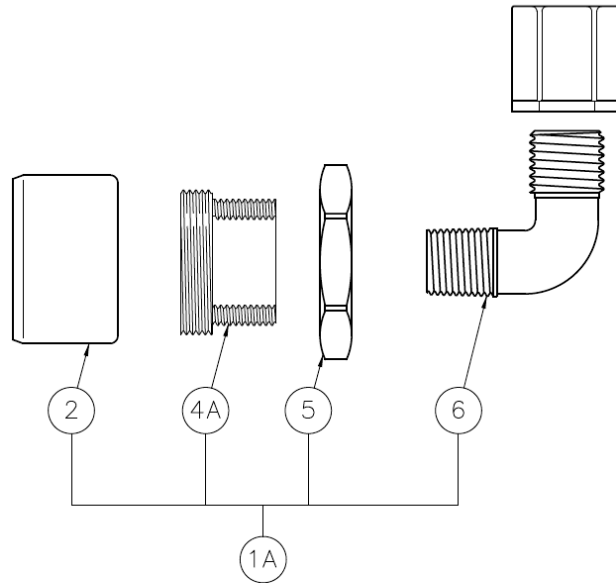

1A	2998-210-001	COMP NOZZLE ASSY -STRAIGHT	4A	2998-210-199	STRAIGHT NOZZLE ADAPTER
1B	2998-212-001	COMP NOZZLE ASSY -20° ANGLE	4B	2998-201-299	20° NOZZLE ADAPTER
1C	2998-204-001	COMP NOZZLE ASSY -30° ANGLE	4C	2998-204-199	30° NOZZLE ADAPTER
2	2998-017-000	.5 GPM FLO-CONTROL NOZZLE ASSY -FEM	5	0312-010-199	3/4"-28 BRASS NUT
3	2998-016-000	.5 GPM FLO-CONTROL NOZZLE ASSY -MALE	6	1895-151-000	1/8" NPT x 1/4" COMPRESSION ELL
ITEM	PART NUMBER	DESCRIPTION	ITEM	PART NUMBER	DESCRIPTION

Valve Detail
Drawing reference: 9905-006-001

Hand / Foot Operation

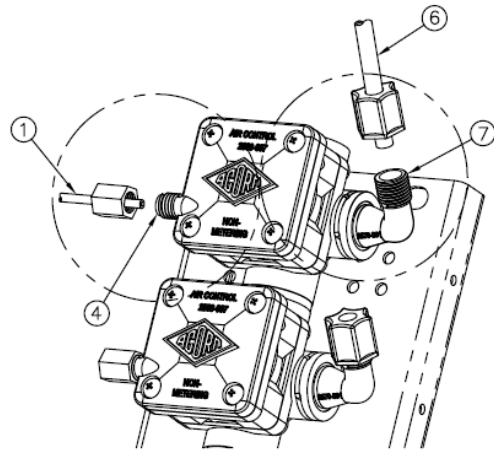
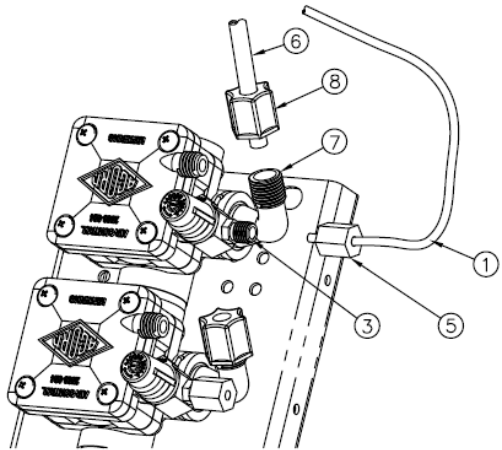
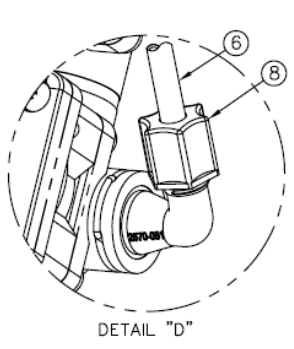
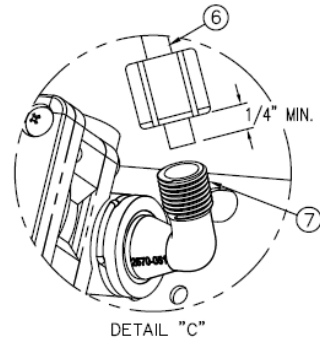
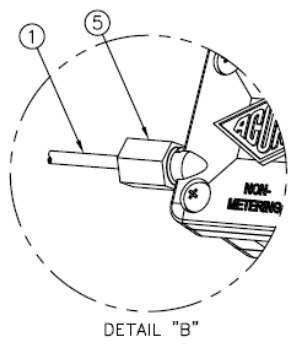
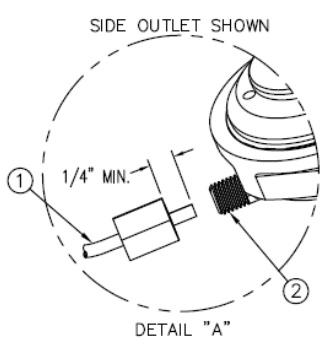

METERING

NON-METERING DIRECT ACTING

REFERENCE DRAWINGS	
ASSEMBLIES	DRAWING
VALVE BODY	9955-006-003
CHECKSTOP	9956-040-003
FIXTURE TRIM	99578-051-001
AIR-CONTROL SERVOMOTORS	
METERING	9955-000-003
NON-METERING	9955-001-003

INSTALLATION INSTRUCTIONS:

- A- MOUNT FIXTURE IN ACCORDANCE TO MANUFACTURER'S INSTALLATION INSTRUCTIONS.
- B- ASSEMBLE SPOUTS AND PUSHBUTTONS TO FIXTURE.
- C- CONNECT 1/8" O.D. POLYETHYLENE AIR LINE ① TO PUSHBUTTON ②, AND VALVE TIMER ASSEMBLY ③ SEE DETAIL "A". NOTE: FOR DIRECT ACTING: ASSEMBLE TO AIR PORT ④, SEE DETAIL "B". HAND TIGHTEN FERRULE NUT ⑤ PROVIDED.
- D- CONNECT 1/4" O.D. POLYETHYLENE WATER LINES ⑥ TO VALVE ASSEMBLY ELBOW ⑦ SEE DETAILS "C", AND "D". HAND TIGHTEN FERRULE NUT ⑧ PROVIDED.
- E- AFTER THOROUGHLY FLUSHING SUPPLY LINES MAKE UP CONNECTIONS TO VALVE ASSEMBLY INLET(S) 1/2" NPTE OR 1/2" NPS FLEX HOSE AS REQUIRED.

NOTE:

- ALL TUBING SHOULD BE CUT SQUARE AND BE FREE OF BURRS OR DEFORMITIES TO ENSURE A WATER TIGHT CONNECTION.
- EXTEND TUBING AT LEAST 1/4" BEYOND FERRULE NUT BEFORE INSERTING TUBING INTO CONNECTION OPENING BEFORE TIGHTENING.
- TUBING SHOULD BE FREE OF KINKS FOR PROPER OPERATION
- MAXIMUM RECOMMENDED WORKING WATER PRESSURE IS 100 PSI; TEMPERATURE IS 130° F; OUTLET TEMPERATURE IS RECOMMENDED AT A MAXIMUM OF 105° F.

WARNING:

PRIOR TO MAKING INSTALLATION, SUPPLY LINES MUST BE FLUSHED OF ALL FOREIGN MATERIAL SUCH AS PIPE DOPE, CHIPS, SOLDER, ETC. VALVE MUST BE DRAINED PRIOR TO BEING SUBJECTED TO FREEZING TEMPERATURES. MAXIMUM RECOMMENDED OUTLET WATER TEMPERATURE IS 105° F.

Valve Component Parts
Drawing reference: 9955-000-003

Hand Operation

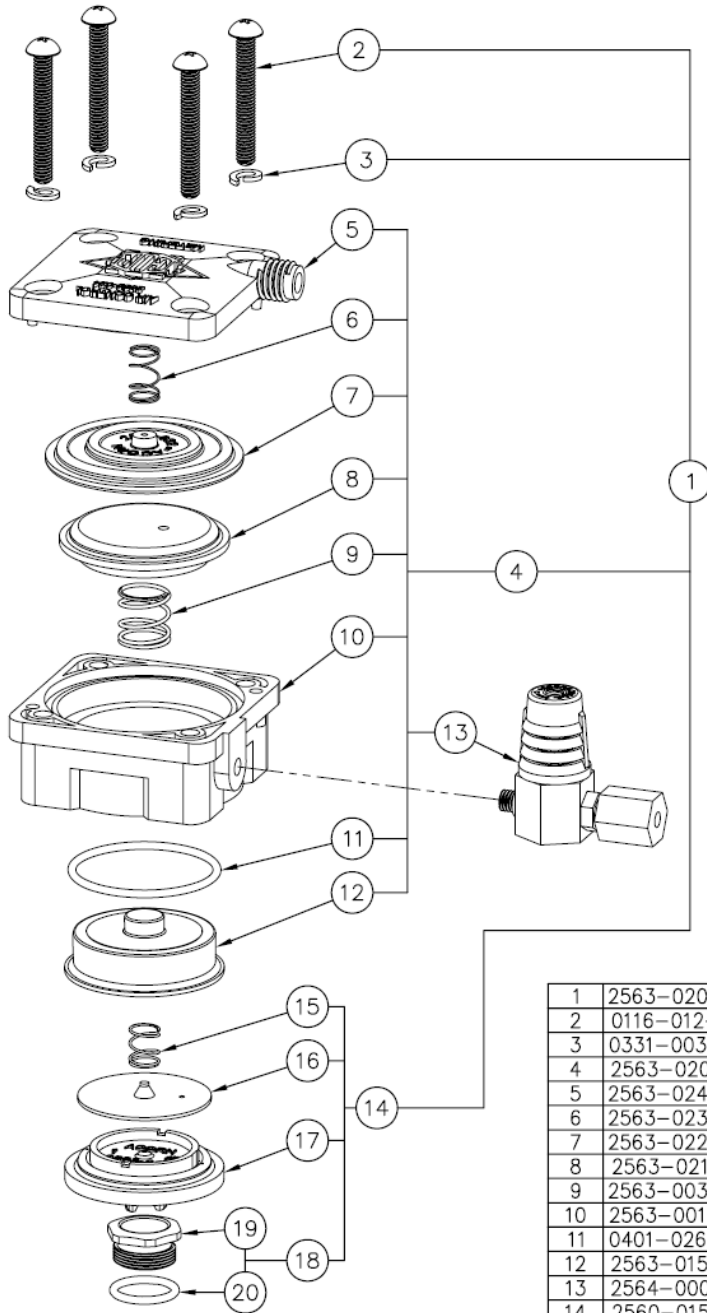

TOP VIEW ITEM # 13

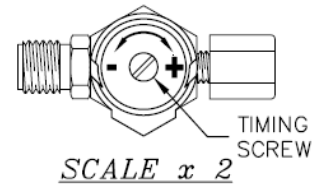

TIMING IS ADJUSTABLE FROM 5 TO 60 SECONDS AND IS ACCOMPLISHED BY ROTATING TIMING SCREW. TURNING THE SCREW CLOCKWISE INCREASES WHILE COUNTERCLOCKWISE DECREASES TIMING.

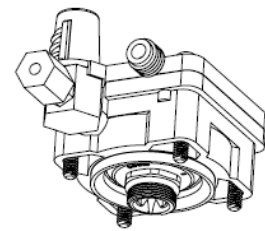

NOTE:
REMOVE ASSEMBLY (18)
FOR PLASTIC BODY INSTALL

1	2563-020-002	AIR-CONTROL METERING ASSEMBLY
2	0116-012-000	8-32 x 1-1/4" LG PHILLIPS ROUND HEAD
3	0331-003-000	#8 LOCKWASHER
4	2563-020-001	METERING MOTOR ASSEMBLY
5	2563-024-000	METERING COVER PLATE
6	2563-023-000	METERING AIR DIAPHRAM SPRING
7	2563-022-000	METERING AIR DIAPHRAM
8	2563-021-001	MAGNET CUP ASSEMBLY
9	2563-003-000	ACTUATOR SPRING
10	2563-001-000	MOTOR HOUSING
11	0401-026-000	O-RING
12	2563-015-199	SEPERATOR CUP
13	2564-000-001	TIMER ASSEMBLY
14	2560-015-001	SEAT ASSEMBLY
15	2563-008-000	PILOT ORIFACE PLATE SPRING
16	2563-019-001	PILOT ORIFACE PLATE ASSEMBLY
17	2563-010-001	WATER DIAPHRAM ASSEMBLY
18	2580-000-001	SEAT ASSEMBLY
19	2580-000-000	SEAT
20	0401-014-000	SEAT O-RING
ITEM	PART NUMBER	DESCRIPTION

Valve Component Parts
Drawing reference: 9955-001-003

Foot Operation

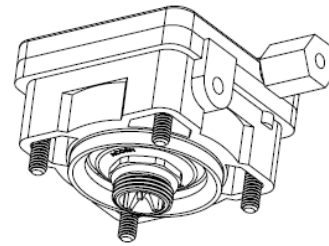
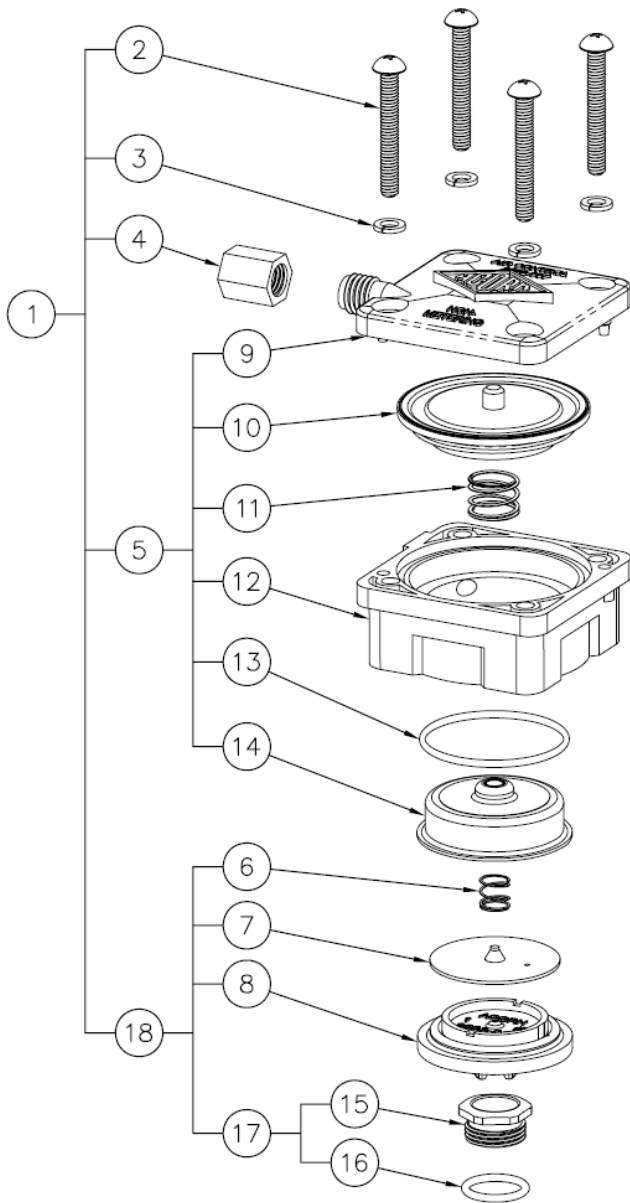

NOTE:
REMOVE ASSEMBLY (17)
FOR PLASTIC BODY INSTALL

1	2563-000-002	DIRECT ACTING ASSEMBLY
2	0116-012-000	#8-32 x 1-1/4" PHILLIPS ROUND HEAD
3	0331-003-000	#8 LOCKWASHERS
4	1895-450-000	1/8" PLASTIC COMPRESSION NUT
5	2563-000-001	DIRECT ACTING MOTOR ASSEMBLY
6	2563-008-000	PILOT ORIFICE PLATE SPRING
7	2563-019-001	PILOT ORIFICE PLATE ASSEMBLY
8	2563-010-001	WATER DIAPHRAM ASSEMBLY
9	2563-007-000	DIRECT ACTING COVER PLATE
10	2563-004-001	DIRECT ACTING DIAPHRAM ASSEMBLY
11	2563-003-000	ACTUATOR SPRING
12	2563-001-000	MOTOR HOUSING
13	0401-026-000	SEPERATOR CUP O-RING
14	2563-002-199	SEPERATOR CUP
15	2580-000-000	AIR-CONTROL VALVE SEAT
16	0401-014-000	BRASS SEAT O-RING
17	2580-000-001	SEAT ASSEMBLY
18	2560-015-001	WATER CHAMBER ASSEMBLY
ITEM	PART NUMBER	DESCRIPTION

Sensor Detail
Drawing reference: 9940-011-001

Sensor Operation

NOTE: RANGE OF MOTION FOR ADJUSTMENT SCREW IS FROM APPROX. 8 O'CLOCK CLOCKWISE TO APPROX. 4 O'CLOCK.

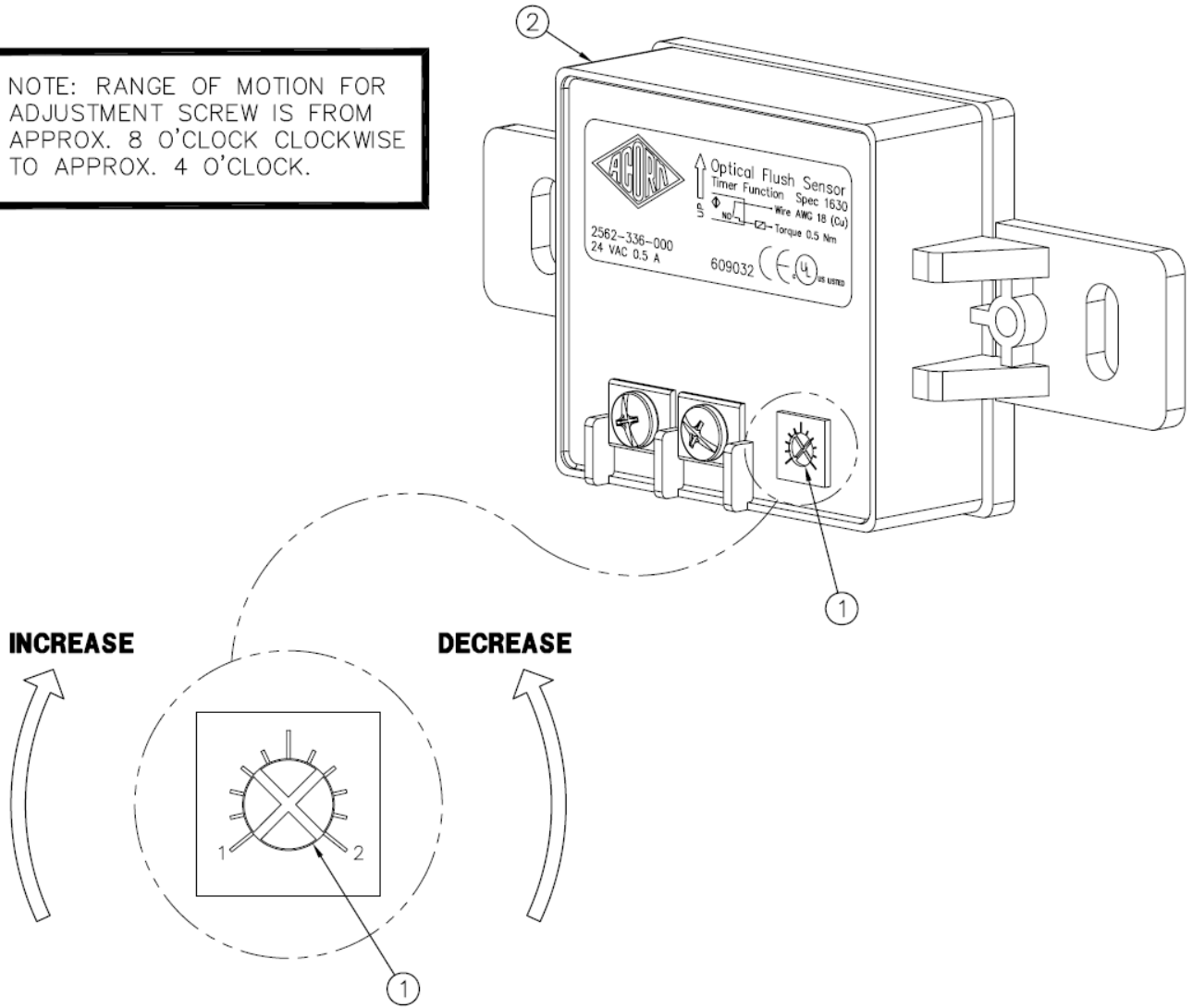

A- USE SMALL JEWELERS CROSS TIP SCREW DRIVER TO ADJUST SENSOR RANGE ① ON BACK OF SENSOR ②.

B- TURN ADJUSTMENT SCREW ① CLOCKWISE TO INCREASE SENSOR RANGE.

C- TURN ADJUSTMENT SCREW ① COUNTERCLOCKWISE TO DECREASE SENSOR RANGE.

D- NOTE: SENSOR RANGE IS FROM 0 TO APPROXIMATELY 24" MAXIMUM.

VALVE DETAIL

Valve Detail and Component Parts
Drawing reference: 9955-015-002

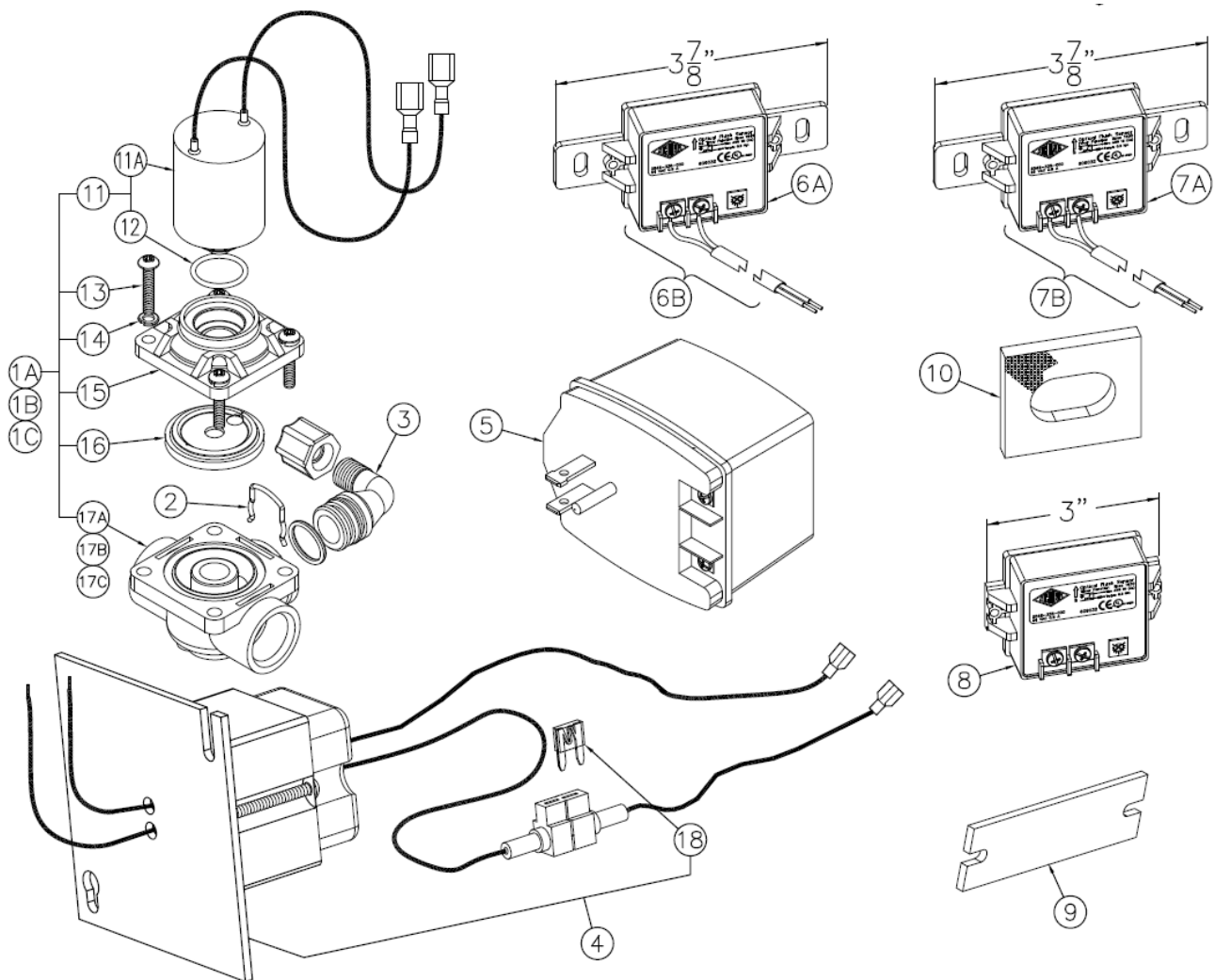

NOTE: WHEN REPLACING THE SENSOR ON CIRCULAR SPRAYHEADS ENSURE TO REPLACE THE SENSOR FOAM GASKET AS WELL.

1A	2570-117-001	P VALVE ASSY w/ 24VAC SOLENOID -LH	10	2562-320-000	SENSOR FOAM GASKET, SS WASHFOUNTAINS
1B	2570-116-001	P VALVE ASSY w/ 24VAC SOLENOID -RH	11	2563-305-002	24VAC SOLENOID ASSEMBLY w/ O-RING
1C	2570-115-001	P VALVE ASSY w/ 24VAC SOLENOID -MA	11A	2563-305-001	24VAC SOLENOID ASSEMBLY LESS O-RING
2	0326-100-000	RETAINING CLIP -PLASTIC AIR-CONTROL	12	0401-117-000	O-RING
3	2570-051-001	1/4" OD PLASTIC ELBOW ASSEMBLY	13	6502-043-000	#8-32 x 1/2" LONG PHIL RND HEAD
4	0710-700-001	120 VAC / 24VAC XFMR ON 4" SQ. PLATE	14	0331-003-000	#8 SPLIT LOCKWASHER
5	0710-725-000	120 VAC / 24VAC PLUG-IN TRANSFORMER	15	2570-061-000	PLASTIC SOLENOID BONNET
6A	2562-336-000	24VAC SENSOR, LESS TIMER	16	2563-010-001	WATER DIAPHRAGM ASSY
6B	2562-336-001	24VAC SENSOR w/ WIRE, LESS TIMER	17A	2570-027-000	PLASTIC VALVE BODY -LH
7A	2562-335-000	24VAC SENSOR, TIMER	17B	2570-026-000	PLASTIC VALVE BODY -RH
7B	2562-331-001	24VAC SENSOR w/ WIRE, TIMER	17C	2570-025-000	PLASTIC VALVE BODY -MANIFOLDING
8	6210-059-199	24VAC SENSOR, TIMER, 3"	18	0713-060-000	3 AMP, 32 VOLT MINI FUSE
9	2562-334-000	24VAC SENSOR LENS			
ITEM	PART NUMBER	DESCRIPTION	ITEM	PART NUMBER	DESCRIPTION

PUSH BUTTON DETAIL

HAND OPERATION

Drawing reference: 9957-300-001

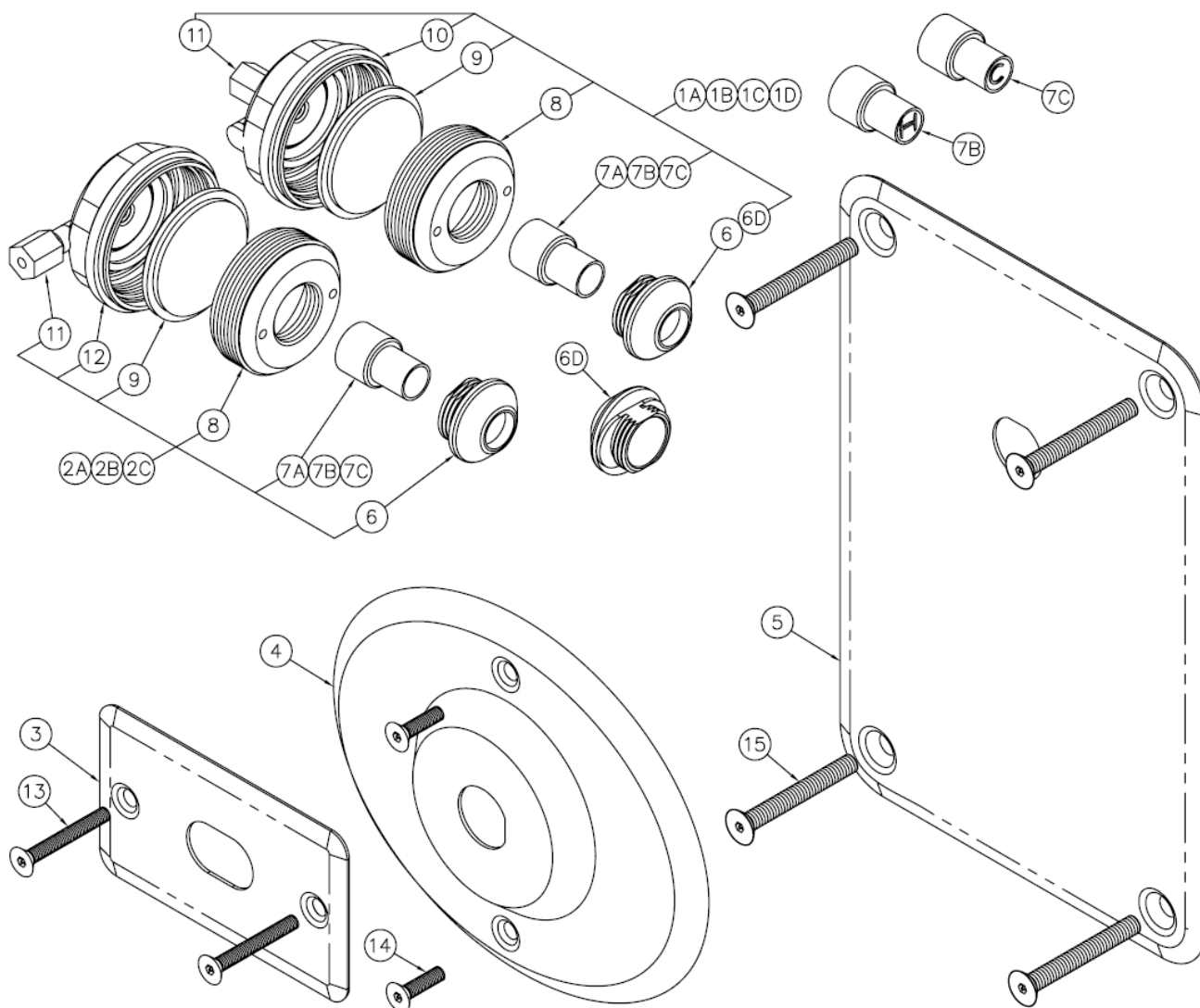

1A	2566-050-001	PUSHBUTTON ASSY, BACK OUTLET -S/T	7A	2566-025-000	PUSHBUTTON -S/T
1B	2566-051-001	PUSHBUTTON ASSY, BACK OUTLET -HOT	7B	2566-026-000	PUSHBUTTON -HOT
1C	2566-052-001	PUSHBUTTON ASSY, BACK OUTLET -COLD	7C	2566-027-000	PUSHBUTTON -COLD
1D	6210-055-001	CORTERRA PB ASSY, BACK OUTLET -S/T	8	2566-022-000	ESCUTCHEON RETAINER
2A	2566-025-001	PUSHBUTTON ASSY, SIDE OUTLET -ST	9	2566-001-000	DIAPHRAGM
2B	2566-026-001	PUSHBUTTON ASSY, SIDE OUTLET -HOT	10	2566-056-199	DIAPHRAGM RETAINER -BACKOUTLET
2C	2566-027-001	PUSHBUTTON ASSY, SIDE OUTLET -COLD	11	1895-450-000	1/8" FERRULE NUT
3	6210-054-199	CORTERRA FRONT PLATE / ESCUTCHEON	12	2566-055-199	DIAPHRAGM RETAINER -SIDE OUTLET
4	2705-008-199	SHOWER-WARE OVAL ESCUTCHEON	13	0152-003-000	#10-32 x 1-1/2" LONG FLT HD CNTR RJ
5	2705-009-199	ZENITH AIR-CONTROL ESCUTCHEON	14	0152-006-000	#10-32 x 3/4" LONG FLT HD CNTR RJ
6	2566-020-199	PUSHBUTTON ESCUTCHEON	15	0152-504-000	1/4-20 x 2" LONG FLT HD CNTR RJ
6D	6210-055-199	CORTERRA PUSHBUTTON ESCUTCHEON	16		
ITEM	PART NUMBER	DESCRIPTION	ITEM	PART NUMBER	DESCRIPTION

PUSH BUTTON DETAIL

FOOT OPERATION

Drawing reference: 9957-200-001

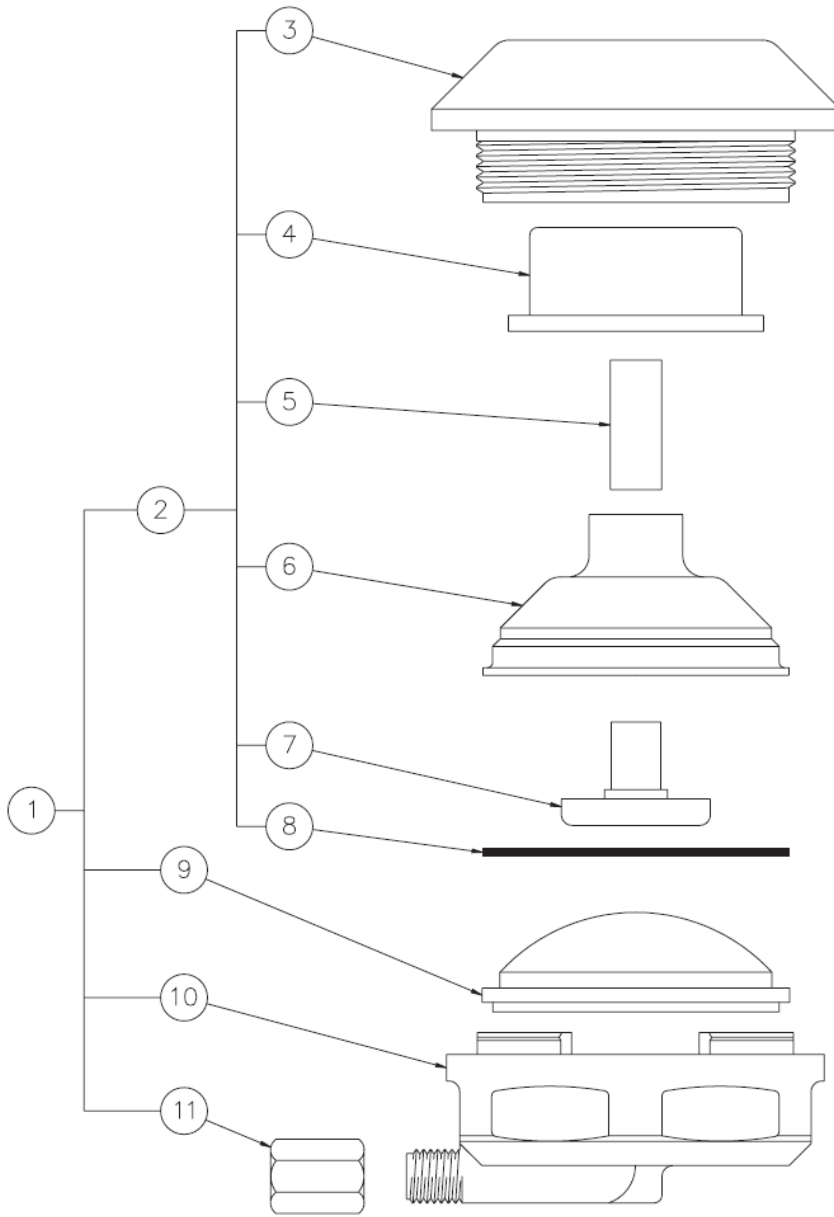

1	2566-010-001	FOOTBUTTON ASSY -COMP	7	2566-004-000	DIAPHRAGM ACTUATOR
2	2566-000-002	FOOTBUTTON GUIDE ASSY	8	2566-008-000	FRICTION RING
3	2566-003-000	ESCUTCHEON	9	2566-001-000	DIAPHRAGM
4	2566-005-000	PUSHBUTTON	10	2566-000-199	DIAPHRAGM RETAINER
5	2566-007-199	TUBULAR GUIDE	11	1895-450-000	1/8" PLASTIC COMPRESSION NUT
6	2566-002-000	BUTTON GUIDE & STOP			
ITEM	PART NUMBER	DESCRIPTION	ITEM	PART NUMBER	DESCRIPTION